

WAVIN Hep_vO™
SELF-SEALING WASTE VALVE
Product and Installation Guide



The Hygienic Alternative to a P-trap

Protect Against Odour. Protect Your Health.





Living Spaces with Clean Air

Sewer air contains noxious gases, viral pathogens and bacteria, which are harmful to our health and well-being. As a dry-sealing valve that utilises a purpose designed membrane, Hep_vO™ helps to prevent sewer gas entering the living space. The self-sealing valve opens under the water pressure of a fixture emptying, and closes to form a tight seal after the fixture has discharged. With this airtight seal between living spaces and drainage systems, Hep_vO™ ensures cleaner and healthier breathing air.

“It has been shown that if a Hep_vO™ had been used as a trap in the Amoy Gardens apartments in Hong Kong, then the alleged cross contamination of the SARS virus would have been prevented.”

- Heriot Watt University, 2005 (Study into the 2003 Hong Kong SARS outbreak)

System Benefits

From professional installers to end users and system designers, the Hep_vO™ dry self-sealing valve offers a variety of benefits to all.



Permanent odour prevention

Unlike conventional traps, Hep_vO™ provides permanent protection even if a fixture is infrequently or never used. It also promotes hygiene by preventing build up of stagnant water and bacterial growth - see **Figure 1** below.



Unaffected by siphonage

Hep_vO™ does not rely on a water seal. Its sealing performance is unaffected by changes in waste system air pressure.

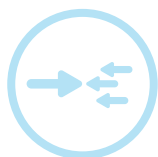

Resistance to back pressure

Hep_vO™ will perform under back pressures, which are 10 times greater than those experienced in a typical soil and waste system.



Space saving

Flexible installation (vertically or horizontally) that allows placement of more fixtures on fewer discharge pipes, without compromising on the performance of the sanitary discharge system.



No branch air admittance valves required

Hep_vO™ actively eliminates negative pressure within the waste system by opening and allowing fresh air in until a state of equilibrium is achieved. It subsequently closes to reseal the waste system and prevent foul air release.



Unaffected by solid or greasy materials

Hep_vO™ continues to perform despite the release of hot or cold fats. Comparative tests have revealed that conventional traps are less effective when fat comes into contact with cold water. The flexibility of Hep_vO™ valve seal prevents the accumulation of limescale and other debris.



Low noise

Say goodbye to “gurgling” noises typically associated with siphonage or a breach in the water seal barrier. Hep_vO™ operates silently even when subjected to a range of abnormal pressures.



Higher flow rate of discharge water

Hep_vO™ allows discharge water to pass easily through, regardless of volume.

Figure 1. Water held in conventional traps can become stagnant (Residues in the water trap can be fermented and produce odours and unhealthy air)

*Suspended matter in water
e.g. soap/scum/grease/saliva etc.*

*Solid matter e.g. decomposing food particles/
hair strands/skin flakes/nail clippings etc.*

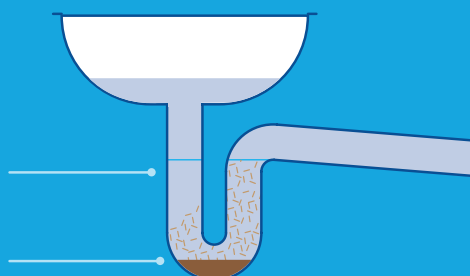

Water Seal Weakness

Conventional waste traps work by having a water seal to prevent foul odours from entering buildings. However, a water trap can fail under a number of conditions. The following diagrams show several problems that result in loss of water seal, gurgling and foul smells.

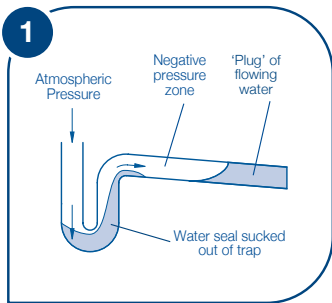

Self Siphonage

Water flowing down the discharge pipe draws the water from the trap.

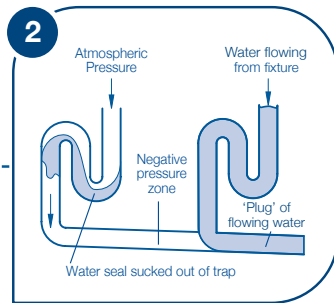

Induced Siphonage

The water seal is drawn out of the trap by water discharging from a fixture downstream (e.g. washing machine).

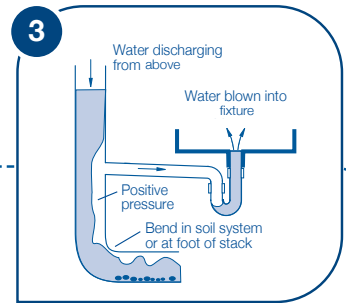

Compression

Water is pushed out of the trap by a positive pressure caused by discharging of fixtures located above (e.g. WC).

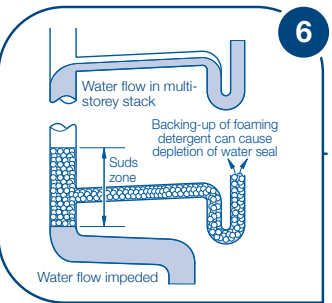

Foaming

Agitation of waste water containing detergents in the Soil and Vent pipe creates foaming which pushes water out of the trap.

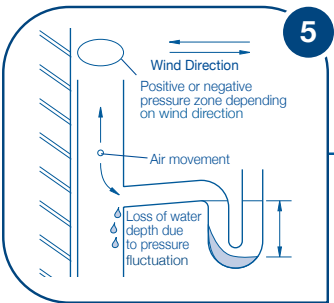

Wind Direction (Wavering Out)

Air movement across the top of the Soil & Vent Pipe causes reciprocation of water in the trap and potential for loss of seal depth.

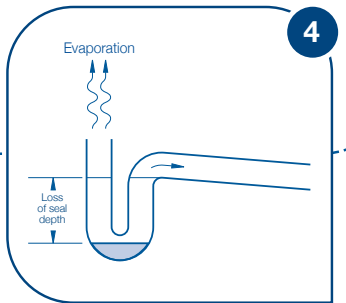

Evaporation

Water in the trap evaporates during periods of non-use (e.g. during vacation or when fixtures are not being used).

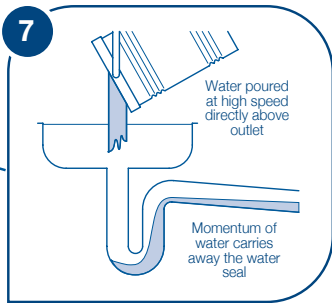

Momentum

Waste water from a bowl or pail poured directly into the waste outlet, carries water out of the trap due to speed of discharge. This is also common with modern, funnel-shaped basin designs.

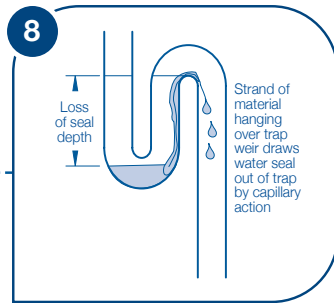

Capillary Action

Fibrous material retained in the trap and hanging over the weir draws water out of the trap.

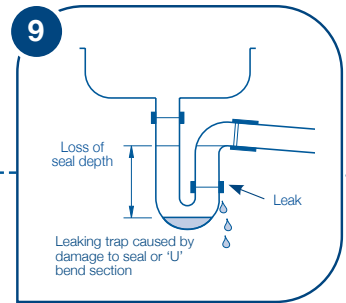

Leakage

Badly fitting or loose components and/or damaged seals can allow water to leak, causing loss of seal depth.

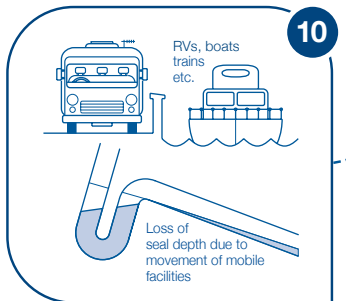

Movement

In mobile facilities such as RVs and boats, movement can cause potential for loss of water in the trap.

The Solution

When installed in accordance with manufacturer's instructions, the unique Hep_o™ Sanitary Waste Valve is the solution to all these problems.

Hep_o™ provides a constant seal against sewer gas ingress, which is maintained under all normal operating conditions. Hep_o™ Sanitary Waste Valve actively eliminates negative pressure within the waste system by opening and allowing fresh air in until a state of equilibrium with atmosphere is achieved. Hep_o™ Sanitary Waste Valve resists blockages, prevents nasty smells, gurgling sounds and stagnant water under all circumstances.

Hygienic Self-Sealing Waste Valve

Replacement for water traps in waste drainage:



Hep_vO™ can be a more effective alternative to traditional waste traps regardless of the types of fixtures and sanitary systems. This includes primary and secondary ventilated systems, stub stacks and where fixtures connect to a gully.

Its sleek design and ability to install vertically or horizontally delivers space-saving, time-saving, simpler system design and cost-saving benefits.

Space Saving

Where required, the waste pipe can drop in a straight line from the fixture outlet, which means that installation access for slimline pedestals is significantly enhanced. **See above left picture.**

For kitchen sinks, installing Hep_vO™ can free up the cupboard space below the sink; particularly an issue when homeowners require integrated waste bins. See **Figure 2 and above centre picture.**

Hep_vO™ can be installed horizontally by using the elbow adapter, which avoids cutting the floor under baths and showers to accommodate the 'U' bend of a trap.

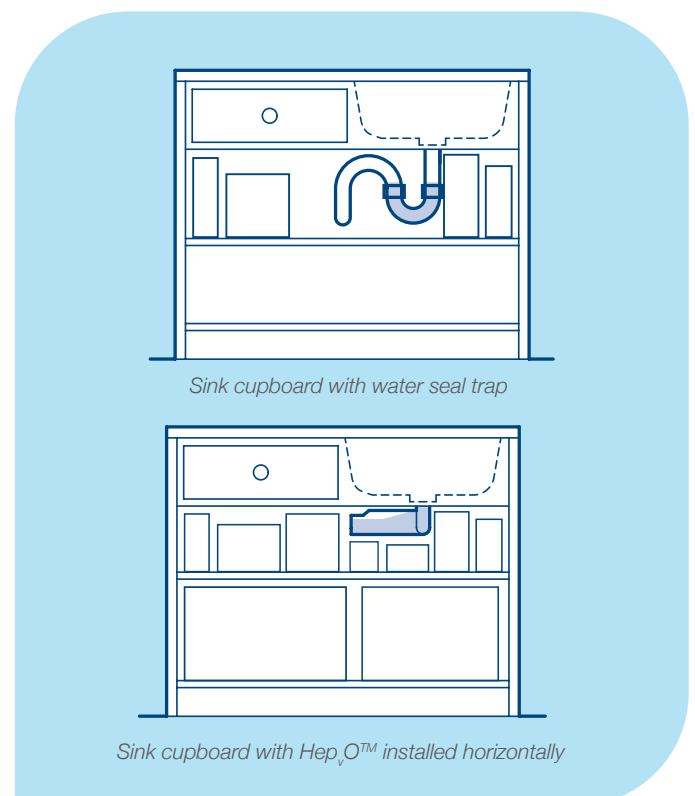

Figure 2: Space-saving capabilities under a kitchen sink

For Branch Pipe Ventilation

Hep_vO™ can act as an air admittance valve, allowing air into the drainage system when negative pressure occurs. Once equilibrium is reached, the valve closes. Using the valve as an air admittance tool provides cost savings, as it eliminates the need for a traditional open vent pipe or a branch air admittance valve. This simplifies system design, providing space and time-saving benefits.

Since Hep_vO™ provides ventilation, more flexibility in pipe sizing is enabled. It allows the pipe run to be extended to 3m without increasing pipe size from 32mm to 40mm when going beyond 1.7m - see **Figure 3**.

Figure 3. Schematic view for extended pipe run

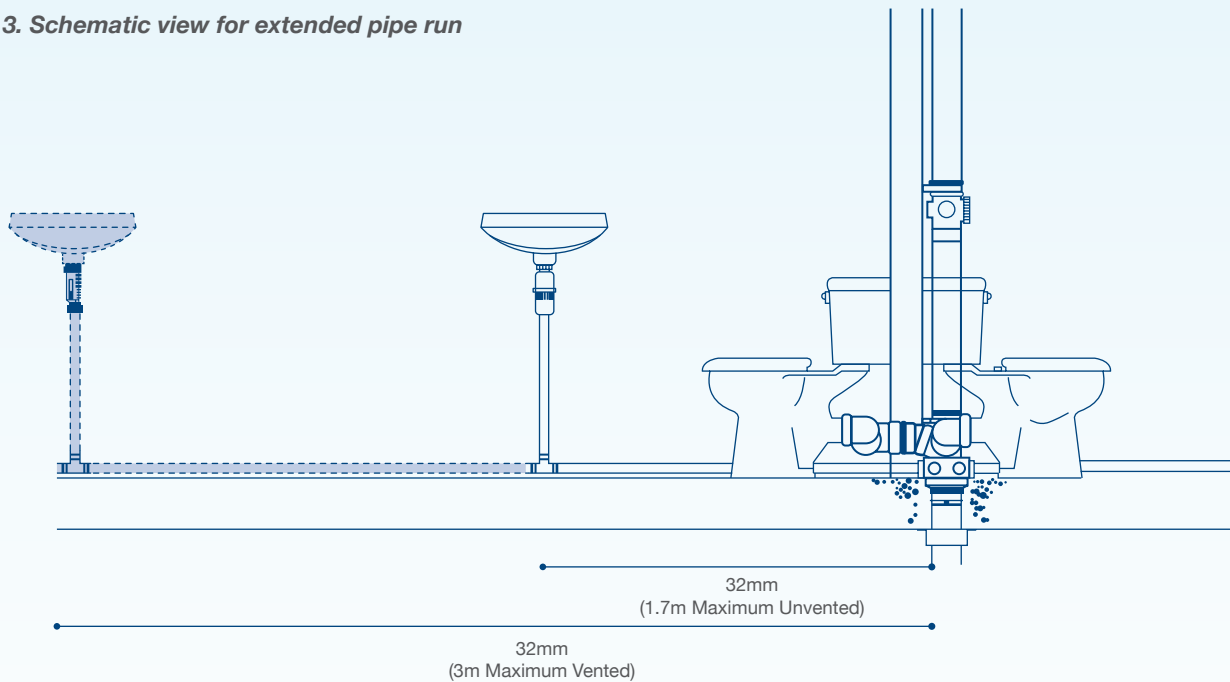

For non-domestic situations, the use of multiple Hep_vO™ valves allows for simpler systems with less pipework & straight runs – see **Figure 4**.

When installation is complete, performing self siphonage and induced siphonage tests for branch discharge pipes from waste fixtures is unnecessary.

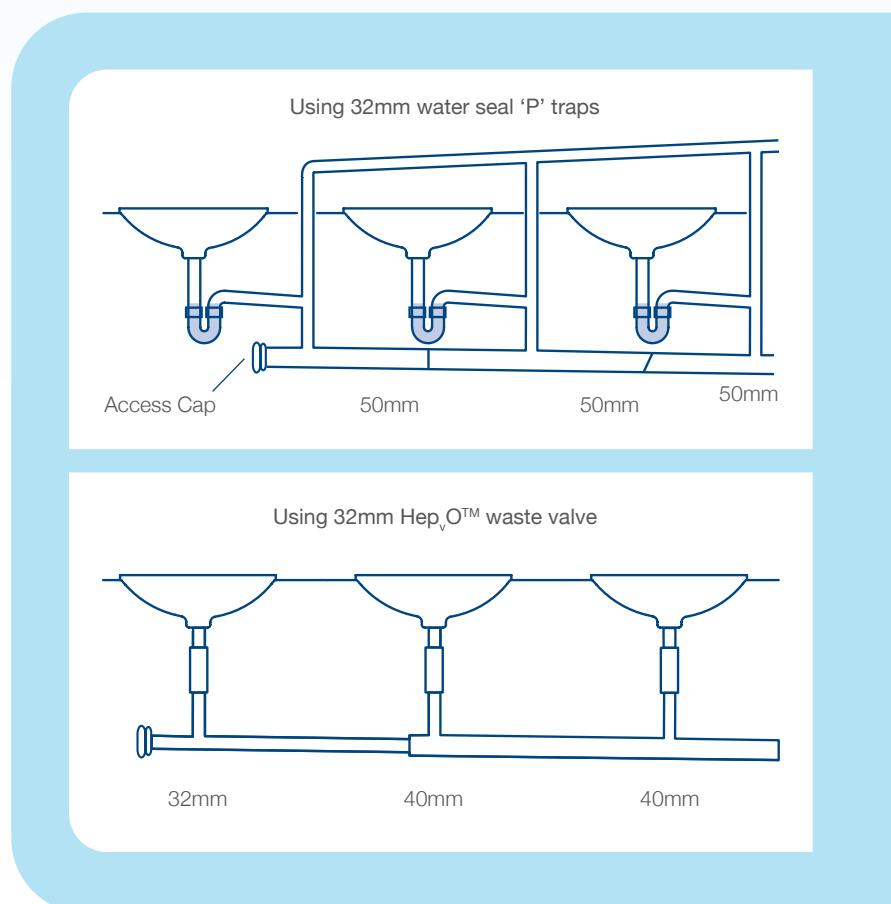

Figure 4. Schematic view for three basins

Hygienic Self-Sealing Waste Valve

Recreational vehicles - such as boats, caravans, etc.

Hep_vO™ works perfectly in any kind of home. Since Hep_vO™ is a self-sealing waste valve, it also performs successfully in motor homes and other moving vehicles - such as boats and caravans - where water traps can lose their seal through movement and vibration.

This also helps to avoid odour-related issues involving water seal freezing, evaporation of water seal in warm weather or extended periods of non-use.

See **Diagram 10** on **Page 3**



Hygienic self-sealing waste valve - for when you're on the move.

For hot climates or where fixtures are used infrequently

Being a waterless trap system, Hep_vO™ is perfect in situations of infrequent use including vacation homes, guest bathrooms, seasonal occupancy hotels and recreational vehicles.

If the fixture is not used for an extended period, evaporation of water in the traditional water trap will lead to a loss of the water seal. In hot climates, with a higher risk of rapid water evaporation, this can be a particular problem, leading to odours escaping into the buildings after a relatively short period of time.

Though deeper water seal traps can be used, they require more space close to the fixture. Hep_vO™'s slimline design is an ideal alternative in this situation.

See **Diagram 4** on **Page 3**

Conventional waste traps can lose their seal if not used on a regular basis.

Drainage from condensate discharge and unvented boiler systems

The Hep_vO™ valve may be used in condensate piping from high-efficiency boilers and air conditioning units discharging directly to sanitary pipework.

- see **Figure 5** below

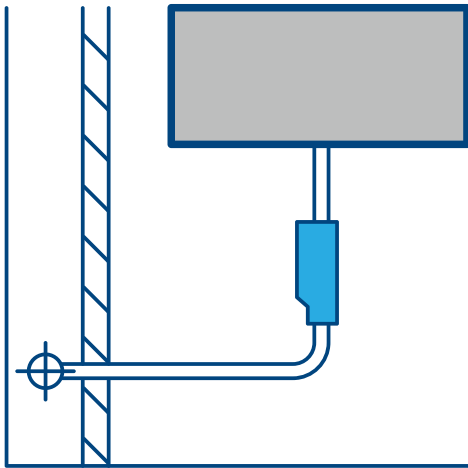

Figure 5. Self-sealing valve when used for condensate discharge



Hep_vO™ can also be used with an unvented hot water storage system to connect a tundish outlet pipe to a drainage stack. This stops the emission of foul air from drainage systems into premises. Using the Hep_vO™ tundish adapter kit, the connection from unvented hot water discharge fixtures to soil stacks is simplified. The kit reduces the number of fittings required, eliminating the need for an in-line adapter. For more details on this application and the tundish adapter kit, please contact Wavin.

Note

- ⚠ This application is not recommended for combi or sealed boiler systems.
- ⚠ Hep_vO™ should not be used for uncontrolled, high temperature discharges such as from pressure-only relief valves (i.e. not incorporating a temperature relief valve).

Hep_vO™ Installation

Hep_vO™ should be installed in accordance with the instructions given here.

Orientation

When fixed horizontally to a fixture outlet or to a sloping pipe Hep_vO™ must be installed with the ribs underneath – see **Figure 6** below. This prevents standing water and provides a continuous fall when used in combination with the Hep_vO™ angled adapter.

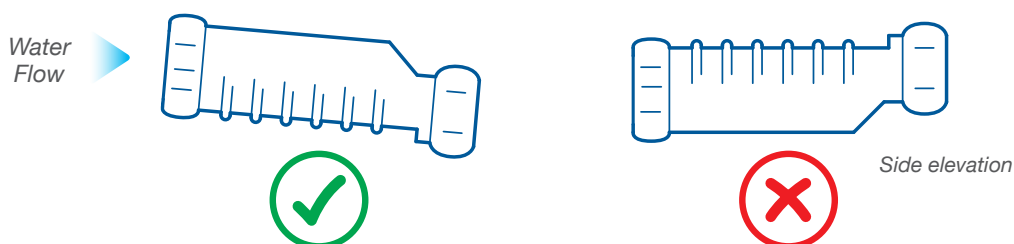
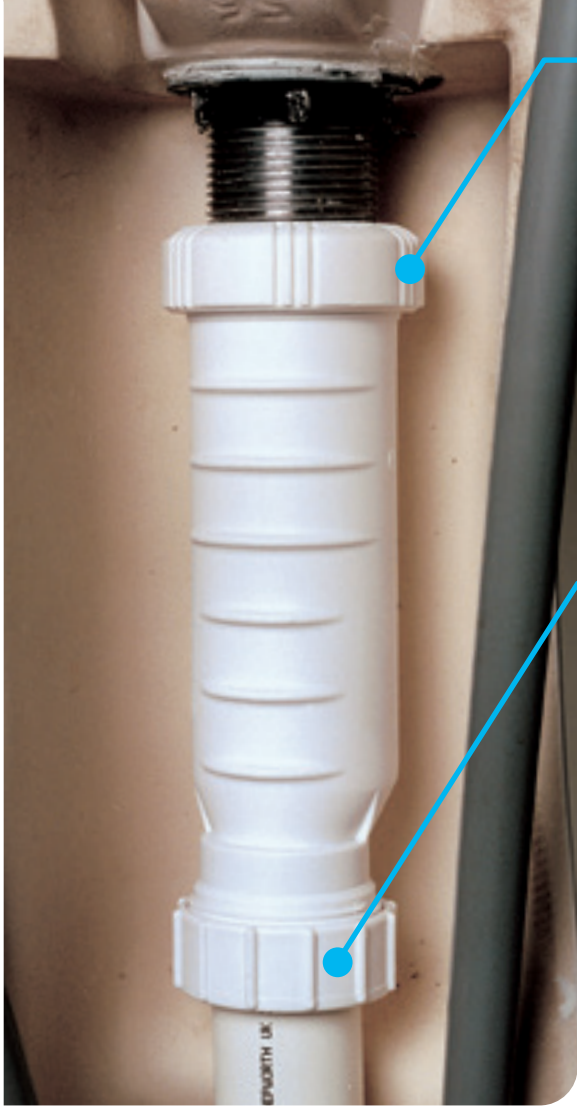

Figure 6.

When installed horizontally the ribs must be at the bottom to ensure correct operation.



Hep_vO™ Inlet

The inlet is provided with a screwed cap and sealing ring, designed to connect to waste fittings conforming to BS EN 274, or to a Hep_vO™ inlet adapter.

Joining

Offer up the Hep_vO™ inlet to the threaded tail of the fixture waste outlet or Hep_vO™ elbow or in-line adapter, and tighten the threaded cap sufficiently hand-tight to provide a water-tight seal (check that the cap screws on square and does not 'cross-thread'). When the screwed cap is tight, the Hep_vO™ body is secure.

Hep_vO™ Outlet

The outlet is provided with a universal compression connection which is designed for use with (1) 'UK Metric' 32 or 40mm waste pipes to BS EN 1451 Part 1 (or equivalent) or (2) 'DN Metric' 32 or 40mm waste pipes.

Joining

1. Cut the pipe to length, allowing for the full compression socket depth using an appropriate pipe cutter.
2. Remove any 'swarf' from the end of a plastic pipe. If using a copper pipe, ream the pipe end to remove any 'burr', and file if necessary to remove any external sharp edges. Mark the socket depth on the pipe, and check that the pipe section to be jointed is free of any surface damage which may affect the joint seal.
3. Unscrew the cap from the Hep_vO™ outlet, and slide the cap and rubber seal onto the pipe – see **Figure 7**.
4. Insert the pipe end fully into the socket.
5. Slide the rubber seal and screwed cap up against the face of the socket, and tighten the cap sufficiently hand-tight (check that the cap is square to the body and does not 'cross-thread').

NOTE: Do not use any jointing compound or sealant on the Hep_vO™ inlet or outlet connections.

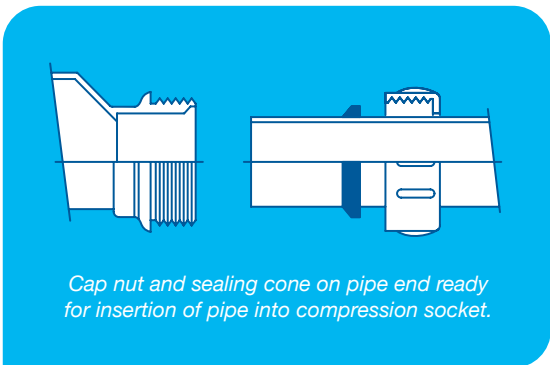

Figure 7. Hep_vO™ outlet connection.

NOTE: For connection to other pipe sizes (for example 50mm) it is possible to make threaded connections to pipe adapters at the Hep_vO™ inlet and outlet. In the case of the outlet, it is then necessary to discard the compression joint components and use Teflon tape before making connection onto the male threads.

Hep_vO™ can be used on any waste fixture. The installation arrangement will depend on the dimensional design of the fixture and site constraints. **Figure 8** shows some of the mounting options for Hep_vO™. Hep_vO™ can be fixed directly to the waste outlet of a fixture. By using the appropriate adapter, it can also be mounted in the horizontal position either at the fixture or on the pipe.

If a Hep_vO™ valve is fitted horizontally, it should be in combination with the Hep_vO™ angled adapter to ensure correct minimum drainage slope or connected to pipework with a drainage slope no less than 18mm per metre. Note that in some applications (urinals and kitchen sinks with waste grinders) installation must be vertical.

Figure 8.
Hep_vO™
Mounting
Options

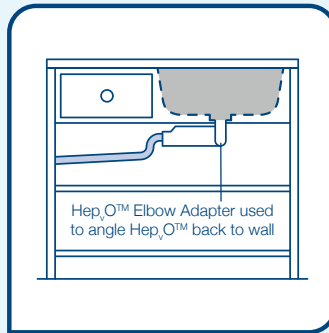

Sink

- 1 x No. 40mm Hep_vO™
- 1 x No. 40mm Hep_vO™ Elbow Adapter
- 2 x No. 40mm Bends

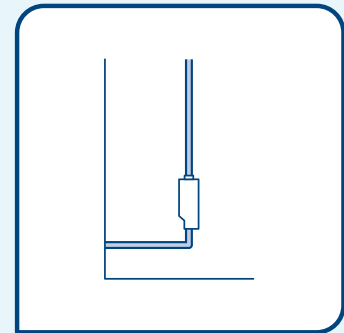

Washing Machine / Dishwasher

- 1 x No. 40mm Hep_vO™
- 1 x No. 32mm Hep_vO™ In-line Adapter
- 1 x No. 40mm Bend

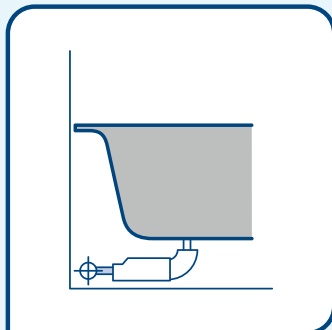

Bath / Shower

- 1 x No. 40mm Hep_vO™
- 1 x No. 40mm Hep_vO™ Elbow Adapter

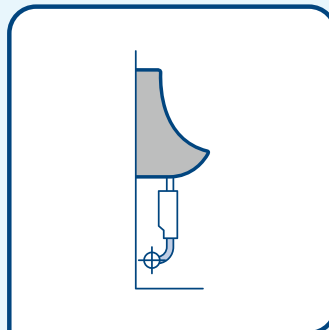

Urinal

- 1 x No. 40mm Hep_vO™
- 1 x No. 40mm Spigot Bend
- Vertical Installation Only*

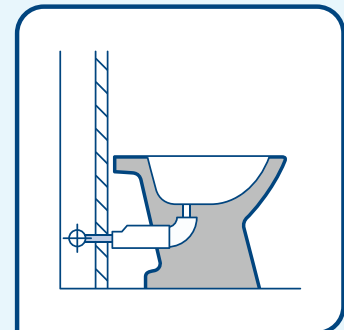

Bidet

- 1 x No. 32mm Hep_vO™
- 1 x No. 32mm Hep_vO™ Elbow Adapter

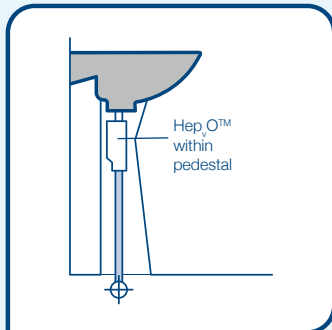

Pedestal Basin

- 1 x No. 32mm Hep_vO™

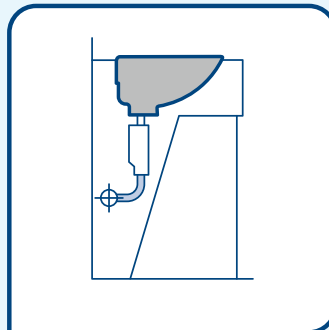

Countertop Basin

- 1 x No. 32mm Hep_vO™
- 1 x No. 32mm Elbow Bend

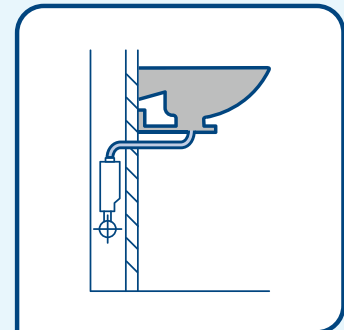

Ducted Basin

- 1 x No. 32mm Hep_vO™
- 1 x No. 32mm Hep_vO™ In-line Adapter
- 1 x No. 32mm Cap & Lining
- 2 x No. 32mm Bends

Waste Piping

Waste pipes should have sufficient slope to convey the likely flow, but should not be less than 18mm/metre in accordance with BS EN 12056 Part 2 or equivalent local regulations. When using Hep_vO™ there is no maximum slope limitation – often a restriction applicable to waste systems using p-traps.

As Hep_vO™ is unaffected by siphonage or compression, combined waste piping can be used to connect more than one fixture to the stack.

Figure 9 shows how Hep_vO™ can be used to simplify the plumbing in a typical bathroom.

Any branch discharge pipes serving fixtures not fitted with Hep_vO™ (e.g. a range of WC's) should be designed and installed in accordance with BS EN 12056 Part 2 or equivalent local regulations.

Discharge stacks should continue to be sized, and vented where appropriate, in accordance with BS EN 12056 Part 2 or equivalent local regulations.

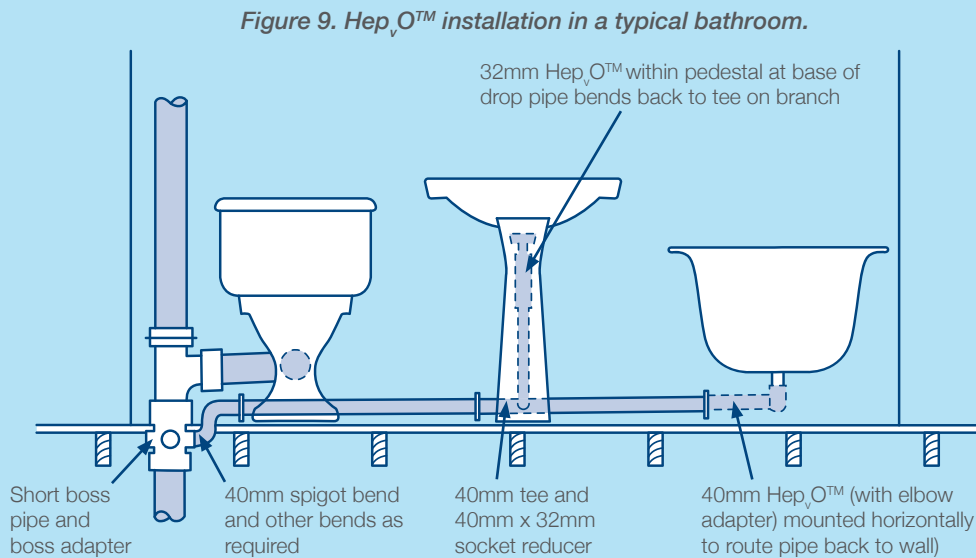

NOTE: Care should be taken to ensure that the underground drainage system is not completely sealed. Natural open ventilation is required at the head of each main drain run and/or at every tenth dwelling.

Operation and maintenance

Operation

Hep_vO™ operates as illustrated in **Figure 10** below. The membrane opens when there is a small positive pressure difference between the inlet and the outlet, for example when a small quantity of water flows into the inlet side. It closes immediately when that pressure difference is negated i.e. when the water has discharged through the valve.

The membrane remains closed in the event that the pressure is higher at the outlet compared to the inlet, resisting sewer odour and back-up of liquid waste. Long term cycle testing and installation experience shows that there is no deterioration in valve-sealing performance after four million opening and closing cycles.

Maintenance

If mechanical devices such as spiral cables, rippers or water jetters are required to clear blockages in the waste system, the Hep_vO™ valve must be removed first.

Caustic drain cleaning chemicals or acid-based cleaners with concentration of up to 10% may be used directly without the need to remove the Hep_vO™ valve. If acid-based cleaners with higher concentration are to be used, then the Hep_vO™ valve must be removed beforehand.

After any maintenance operation, it is good practice to rinse the Hep_vO™ valve thoroughly with clean water before it is replaced or reused in the system.

Figure 10. Operation of Hep_vO™.

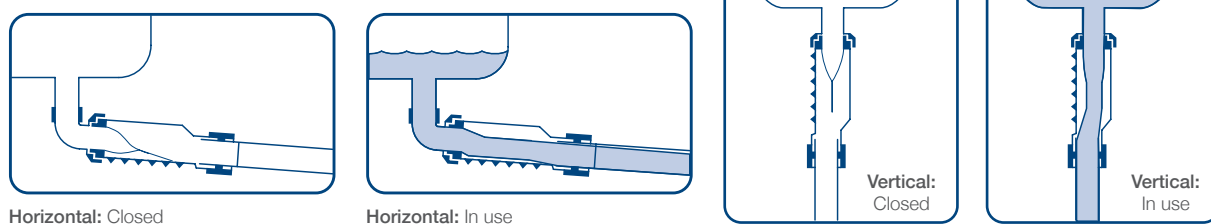

Product Details

The Hep_vO™ valve and elbow adapters are available in sizes 32mm and 40mm. A 87.5° elbow adapter should be used with the Hep_vO™ valve for horizontal applications, and an in-line adapter should be used when installing the Hep_vO™ in a pipe run. All items are manufactured from white polypropylene. Dimensional data for the Hep_vO™ is shown in **Figure 11**.

Hep_vO™ Dimensional Data

Figure 11. Principle dimensions (mm).

SIZE	C	E	L	W	Z	H
32mm	8	171	208	211	40	70
40mm	5	171	208	213	40	73

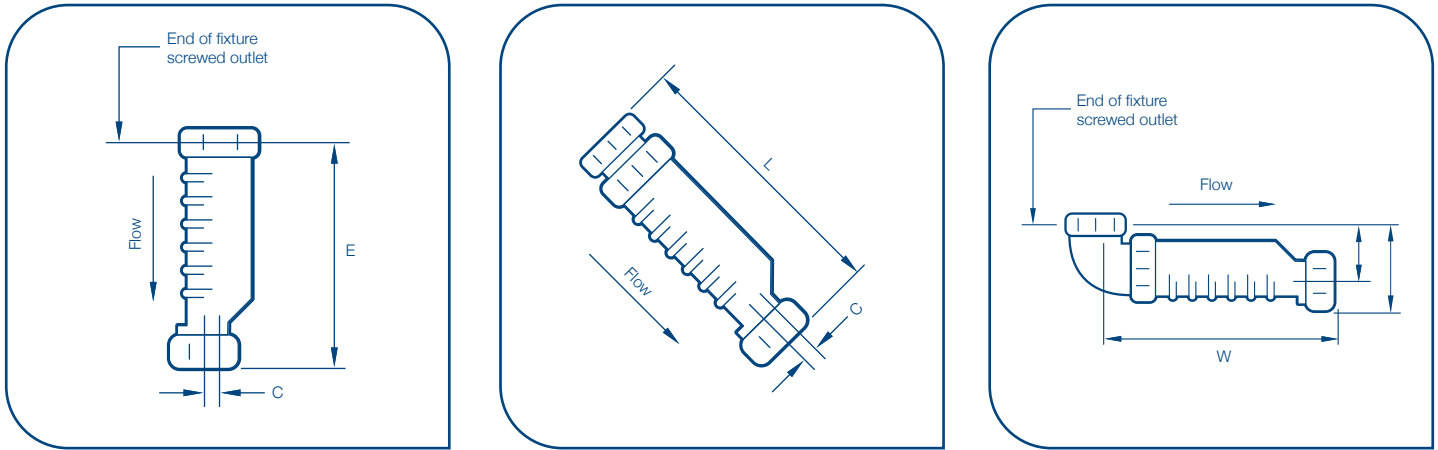

a) Fixed vertically directly to fixture outlet.

b) Fixed on a pipe at any sloping angle using an in-line adapter (available separately)

c) Fixed horizontally to fixture outlet using elbow adapter (available separately)

NOTE:

1. Dimensions are nominal and may vary slightly due to compression of the rubber seals.
2. When fixed to a pipe, it is recommended that Hep_vO™ should remain accessible.

Figure 12. Part Numbers.

System	Inlet Pipe Size (Nominal)	Inlet OD Pipe Size (Actual)	Valve Part No.	Angled Adapter	In-Line Adapter	Threaded Valve Inlet	Valve Outlet
UK	32mm	34.5-36.5	BV1 WH	BV11 WH	BV3 WH	1 1/4"	UK 32mm Pipe
UK	40mm	40.9-43.2	CV1 WH	CV11 WH	CV3 WH	1 1/2"	UK 40mm Pipe
DN Metric	32mm	32.0-32.4	BV1/M WH	BV11 WH	BV3/M WH	1 1/4"	DN 32mm Pipe
DN Metric	40mm	40.0-40.4	CV1/M WH	CV11 WH	CV3/M WH	1 1/2"	DN 40mm Pipe

Special versions compatible with US Tubular Pipe Systems to ASTM-F409 also available upon request.

Quality, Standards & Approvals

All Wavin manufacturing sites operate Quality Management Systems complying with EN ISO 9001 and Environmental Management Systems which comply with the requirements of EN ISO 14001.

The use of Hep_vO™, when installed in accordance with manufacturers' recommendations, will ensure that installations comply with the requirements of BS EN 12056 Part 2 Code of Practice for Sanitary Pipework, and Document H of the Building Regulations 2002 'Drainage and Waste Disposal, with respect to seal integrity.

Hep_vO™ functions without the use of water and complies with all other relevant functional requirements of BS EN 274:

Specification for Plastics Waste Traps. Hep_vO™ also complies with BS EN 15749-1 2004 Ships and Marine Technology – drainage systems on ships and marine structures.

Hep_vO™ is kitemarked to ATS 5200-047:2005 (KM 618560). It also has International Certification including a Watermark License (Australia), Listing to ASME / ANSI A112.18.8 (USA) and CSA Attestation (Canada).



Based on external test results, Hep_vO™ valve has a life expectancy at least equivalent to current water sealed traps.

Case Study

Soccer City Stadium Johannesburg, South Africa



The FNB Stadium, known as Soccer City for the 2010 World Cup, was extensively remodelled for the event. Capacity was increased to almost 95,000 making it the largest stadium in South Africa.

One of the engineering challenges facing any sporting stadium is how best to deal with the volume of spectators needing to use toilets during the event and with the periods between events when there is little or no usage.

The Hep_vO™ Benefits:

“We chose Wavin Hep_vO™ valves for all wastewater, condensate and urinal installations in the stadium rebuild. The valves cannot dry out between usages. They can cope with large flow rates and prevent any chance of odours being released into public areas.”

- Ivan Goldsmith of Goldsmith Plumbing Consultants explains the choice of Hep_vO™.

Another advantage of Hep_vO™ is that it allows pipes and components to be fully concealed. This minimises the risk of vandalism or theft.

Soccer City also uses Hep_vO™ in the air conditioning systems of its executive suites, changing rooms and administration areas. Hep_vO™ allows the air conditioning condensate to be disposed of directly to the soil stack. This is not possible with conventional traps. Around 2000 Hep_vO™ valves were installed at this prestigious and renowned sporting venue.

Hep_vO™ Valve Components

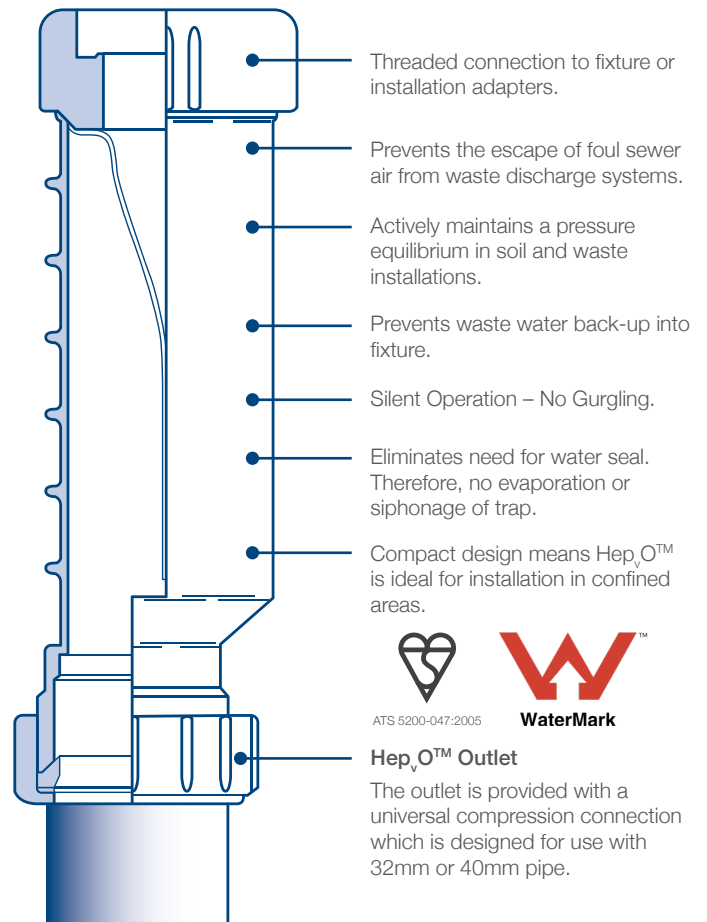

Frequently Asked Questions (FAQs)

1. Is Hep_vO™ used in addition to a conventional trap?

NO, Hep_vO™ is used on its own instead of a conventional water seal trap.

2. Will I still need to install auxiliary venting on waste pipe branches?

NO, Hep_vO™ acts as a highly effective local air admittance device, removing the need for secondary venting.

3. Can I use drain cleaning chemicals?

Hep_vO™ is resistant to standard caustic-based drain cleaners. It is also resistant to acid-based cleaners with concentrations up to 10%. When flushing with higher concentrations of acid-based cleaner, the valve must be removed before the operation. After any maintenance, it is recommended that the valve is flushed through with clean water.

4. Hep_vO™ is a new product to me - how can I be confident that it will give a good installed performance?

Hep_vO™ may be new to some markets, but it is not a new product. It has been in volume production in the UK since 1997 and it is widely used in Europe, Australia and the Americas. It has attained numerous international approvals against very demanding standards and has achieved an enviable track record of trouble-free performance.

5. Will Hep_vO™ promote better hygiene by stopping the escape of foul sewer air into habitable spaces?

YES - The valve has been proven to perform under conditions in which traditional water seal traps are vulnerable to failure. It will continue to perform under back pressures 10 times greater than those experienced in correctly designed soil and waste systems.

6. Does the airtight seal break down if a strand of cloth or hair collects in the strainer and falls down between the faces of the valve?

NO - Hep_vO™ has undergone extensive foreign body testing (For Example: ASME A112.18.8). Tests show that the valve will maintain an airtight seal around an obstruction such as hair, fabric strands or spaghetti.

7. What is the life expectancy of Hep_vO™?

Installed correctly, can be expected to have a life expectancy at least equivalent to current water sealed traps.

8. Will Hep_vO™ block easily for example if fat is discharged through it?

NO - Extensive testing has shown that Hep_vO™ is less prone to blockage than traditional water seal traps. Note: because the 'straight through' design of Hep_vO™ does not trap debris discharged through the waste fixture so care should be taken with jewellery and other valuables.

9. Will the seal be maintained even when the fixture hasn't been used for some time?

YES - Hep_vO™ does not depend on a water seal and so it will continue to maintain a seal whether a fixture never gets used or is used very infrequently.

10. Does the valve make a noise?

Under normal conditions, Hep_vO™ operates silently, unlike normal traps that are prone to 'gurgle'.

11. Will Hep_vO™ support microbiological growth?

NO - The materials used to manufacture Hep_vO™ will not encourage microbiological growth for example mould and mildew.

Distributed by:

0800 246 810

1800 666 952

LEAP AUSTRALASIA LTD
61 Port Road
Seaview
Lower Hutt
New Zealand

LEAP AUSTRALASIA PTY LTD
95b Cheltenham Road
Dandenong
Victoria 3175
Australia



Wavin is part of Orbia, a community of companies working together to tackle some of the world's most complex challenges. We are bound by a common purpose: To Advance Life Around the World.

